

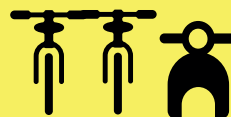

**AUTOMATIC LOADING TRACK
2 BIKES, 2 E-BIKES, 1 SCOOTER**



ENGLISH - NEDERLANDS



LOADING TRACK FOR 2-WHEELERS

Loading your two-wheelers in your camper, requires a significant effort. With the Pollicino loading ramp this problem is solved! The loading ramps will load your equipment easily in your garage in a manual or electronically using a remotecontrol. The installation is very easy and due to the removable clamps, it won't take any space in your garage when not needed. The compact loading rail needs barely space in the rear garage.

SPECIFICATIONS:

- Security lock for the wheels
- Removable clamps
- max consumption 6A-12V
- Just 16KG in weight.
- loads up to 160KG



Bike & e-Bike

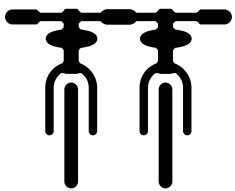

- 1 or 2 bikes or E-bikes.
- Universal clamp for wheels 8"/29"
- Right- or Left hand version
- Manual or Electronic version with remote



Moto & Scooter



- 1 motorbike or Scooter
- Manual or Electronic version with remote
- Universal clamp for wheels 8"/21"
- Right- or Left hand version



PREMIUM RAMP 226cm, max 340KG



LAADBAAN VOOR TWEEWIELERS

Het laden van uw fiets of scooter in uw camper vereist een aanzienlijke inspanning. Met de laadbrug van Pollicino is dit probleem opgelost! Uw tweewieler wordt eenvoudig handmatig of elektronisch (met afstandsbediening) uw camper in getrokken. De installatie van de Pollicino is zeer eenvoudig en door de verwijderbare klemmen neemt deze geen onnodige ruimte in beslag wanneer deze niet nodig is.

SPECIFICATIES:

- Beveiligingsslot voor de wielen
- Verwijderbare klemmen
- max. Verbruik 6A-12V
- Slechts 16 kg in gewicht.
- laadt tot 160KG



Fiets & e-Bike

- 1 of 2 fietsen of E-bikes.
- Universele klem voor 8 “ tot 29” wielen
- Rechts- of linkshandige versie
- Handmatige of elektronische versie met afstandsbediening

Brommer & Scooter

- 1 brommer or Scooter
- Universele klem voor 8” tot 21” wielen
- Rechts- of linkshandige versie
- Handmatige of elektronische versie met afstandsbediening



EASY RAMP 160cm, max 200KG

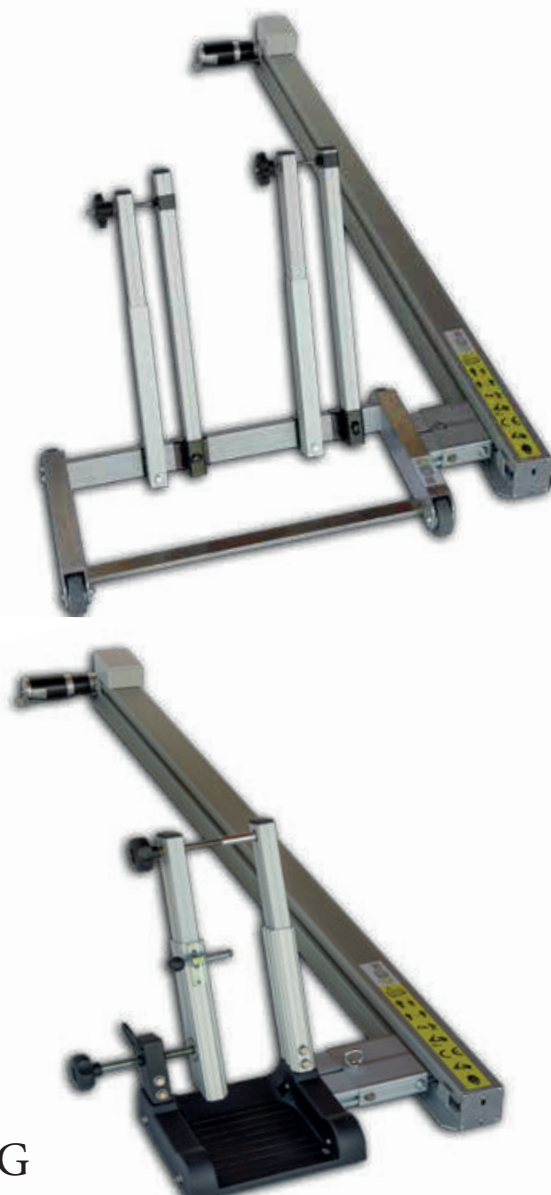



TRABUIO DOMENICO - P.IVA: 01606240263
via Gardan 1/b - 31032 Casale Sul Sile (TV) - Italia
Tel: +39 0422 1741538

Benelux & Scandinavia:

Karman Trading
Telgterweg 301-D 3853 NJ ERMELO, The Netherlands
www.karmantrading.eu
info@karmantrading.eu

Local variations in product range may occur and products may be subject to change without further notice. With reservation against possible mistakes in the contents of the catalogue.